

NORMAPLAST® – Plastic Products

Product & Material Properties

Thermal Properties

For the threaded connecting pieces the coefficient of expansion of 100×10^{-6} must be considered if there is any exposure to temperature fluctuations. Our standard materials are classified under the UL (Underwriters Laboratories) system:

Flammability (UL94)

POM, PP, PA6, PA6.6, and PA12 : **HB** (Horizontal Burning)

Chemical properties of the plastic materials used

No.	Chemical Substance	Concentration	Temperature	POM	PP	PA 6	PA 6.6	PA 12
1	Acetone	100%	20 °C/50 °C	1/3	1/1	1/0	1/0	1/0
2	Formic acid	98–100%	20 °C/50 °C	4/4	1/3	4/4	4/4	4/4
3	Ammonium hydroxide (spirits of ammonia)	Any	20 °C/50 °C	1/2	1/1	1/0	1/0	1/0
4	Fuel (Super Unleaded, Normal)	Commercial	20 °C/50 °C	1/1	3/4	1/1	1/1	1/1
5	Benzene, B. hydrocarbons	100%	20 °C/50 °C	3/3	3/4	1/0	1/0	1/0
6	Bleaching lye (12.5% active chlorine)	Aqueous solution 12,5%	20 °C/50 °C	4/4	3/3	4/4	4/4	3/3
7	Brake fluid (DOT4)	Commercial	20 °C/50 °C	1/1	1/1	1/1	1/1	1/1
8	Butane	Technically pure	20 °C/50 °C	1/2	1/1	1/0	1/0	1/0
9	Chlorine, chlorine water	Commercial	20 °C/50 °C	4/4	4/4	4/4	4/4	4/4
10	Disinfectant phenols	Diluted solution	20 °C/50 °C	4/4	1/1	4/4	4/4	4/4
11	Diesel fuel, Diesel oil	Commercial	20 °C/50 °C	1/1	1/3	1/1	1/1	1/1
12	Decalcifier	Aqueous solution ~ 10%	20 °C/50 °C	4/4	1/1	2/3	2/3	2/3
13	Photographic developer (1:100)	Commercial	20 °C/50 °C	1/1	1/1	4/4	4/4	4/4
14	Town gas (coal gas, natural gas)	Commercial	20 °C/50 °C	1/1	1/1	1/1	1/1	1/1
15	Crude oil	Commercial	20 °C/50 °C	1/1	3/3	1/1	1/1	1/1
16	Acetic acid (glacial acetic acid)	90%	20 °C/50 °C	4/4	1/2	4/4	4/4	4/4
17	Ethyl alcohol	96% (techn. pure)	20 °C/50 °C	1/2	1/1	1/0	1/0	1/0
18	Photographic emulsion	Commercial	20 °C/50 °C	1/0	1/1	1/0	1/0	1/0
19	Fruit juices	Commercial	20 °C/50 °C	1/1	1/1	1/1	1/1	1/1
20	Glycerine	Technically pure	20 °C/50 °C	1/1	1/1	1/1	1/1	1/1
21	Glysantin	Commercial	20 °C/50 °C	1/1	1/1	3/3	3/3	3/3
22	Heating oil	Commercial	20 °C/50 °C	1/1	1/3	1/1	1/1	1/1
23	Hydraulic fluids	Commercial	20 °C/50 °C	1/0	1/3	1/1	1/1	1/1
24	Carbon dioxide, carbonic acid	Technically pure, saturated	20 °C/50 °C	1/1	1/1	1/0	1/0	1/0
25	Coolants (based on Glycol)	Commercial	20 °C/50 °C	1/1	1/1	3/3	1/1	1/1
26	Methane	Technically pure	20 °C/50 °C	1/1	1/1	1/1	1/1	1/1
27	Methanol	Technically pure	20 °C/50 °C	1/1	1/1	1/1	1/1	3/3
28	Methylethylketon	100%	20 °C/50 °C	3/3	1/3	1/0	1/0	1/0
29	HD engine oils	Commercial	20 °C/50 °C	1/1	1/3	1/1	1/1	1/1

NORMAPLAST® – Plastic Products

No.	Chemical Substance	Concentration	Temperature	POM	PP	PA 6	PA 6.6	PA 12
30	Sodium hydroxide	40%	20 °C/50 °C	1/1	1/1	1/1	1/1	1/1
31	Ozone	Gaseous	20 °C/50 °C	4/4	3/4	3/4	3/4	3/4
32	Propanol	Technically pure	20 °C/50 °C	1/1	1/1	1/1	1/1	2/2
33	Propane (liquefied gas)	Fluid	20 °C/50 °C	1/1	1/1	1/0	1/0	1/0
34	Propene	96%	20 °C/50 °C	1/0	1/1	1/0	1/0	1/0
35	Rape oil (RME)	Commercial	20 °C/50 °C	1/1	2/2 (*)	1/1	1/1	1/1
36	Hydrochloric acid	Aqueous, 10%	20 °C/50 °C	4/4	1/1	4/4	4/4	3/3
37	Lubricating oils with HD or or with EP additive	Commercial	20 °C/50 °C	1/1	1/2	1/1	1/1	1/1
38	Sulphuric acid	Aqueous, 10%	20 °C/50 °C	4/4	1/2	3/3	3/3	2/2
39	De-icing salt (solutions)	Saturated	20 °C/50 °C	1/2	1/1	1/1	1/1	1/1
40	Soap suds	Solution, diluted	20 °C/50 °C	1/1	2/2 (*)	1/1	1/1	1/1
41	Water (drinking, river, sea)	Technically pure	20 °C/50 °C	1/1	1/1	1/1	1/1	1/1
42	Citric acid	10%	20 °C/50 °C	2/4	1/1	1/0	1/0	1/0

Abbreviations:

POM = Acetalcopolymersat
 PP = Polypropylen
 PA = Polyamide

0 = No statement available / no declaration possible

1 = Very stable / applicable

(Change in dimensions: none or negligible and reversible; no damage also after long periods of time)

2 = Very stable / applicable

(Change in dimensions: none or negligible and reversible after a short period of time; slightly changed dimensions, possibly irreversible changes in the material characteristics after a longer period of time)

3 = Conditionally applicable

(Change in dimensions: considerable changes; possibly irreversible changes in the material characteristics after a longer period of time)

4 = Not stable / not applicable

(soluble or extremely affected after a short period of time)

(*) Moisture expansion

The details given in this brochure are based on tests carried out by the granulate manufacturer. They are given as guidelines for our customers but cannot be applied to cases where our customers expect these products to meet requirements not covered by testing.

In such cases customers must consult us in advance. Our customers must conduct their own tests to ensure that NORMAPLAST® plastic hose connectors are suitable for their intended

purpose. We would be pleased to provide help and advice in any way. Liability is strictly limited to our general terms and conditions of sale.

Custom versions will be available if a sufficiently large quantity is ordered. Before use as a safety component, please consult the manufacturer. We reserve the right to make technical changes.

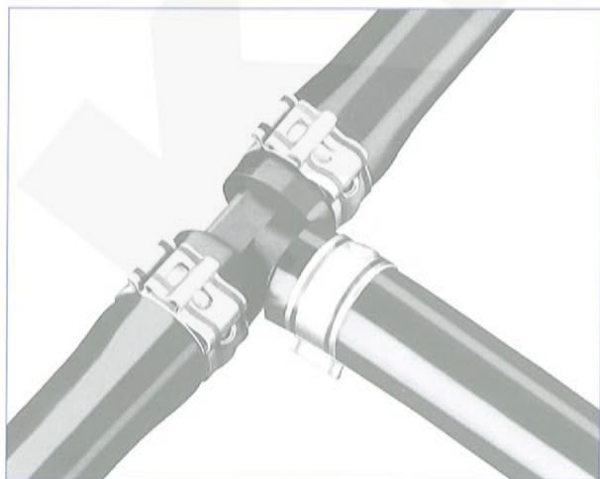

Used as a hose connector

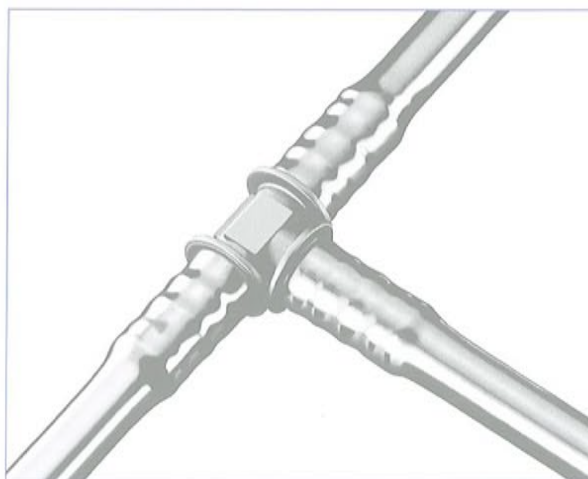

Used as a pipe connector